

Creation and experimental studies of the dynamic measuring concentrations of particulates in the exhaust gases of diesel engines

A. Polivianchuk ¹, I. Parsadanov ², O. Holkina ¹

¹Volodymyr Dahl East Ukrainian National University; e-mail: apmail@meta.ua

²National Technical University "Kharkiv Polytechnic Institute";

e-mail: dvs@kpi.kharkov.ua

Received July 1. 2015; accepted July 20. 2015

Summary. Modern methods for dynamic measurement of mass emissions of particulate matter from the exhaust gases of diesel power plants and requirements for accuracy and high-speed response have been analyzed. A basic diagram as well as a brassboard have been developed for the dynamic particulate emission tester which allows control of instantaneous concentration, mass and specific particulate emissions from various types of diesel engines. Experimental research of the dynamic particulate matter tester shows its practical suitability for determination of particulate emissions in constant and unsteady operating modes of a diesel engine.

Key words: diesel, brake tester, exhaust gases, particulate matter (particulates), concentration, mass emission, dynamic measurements.

INTRODUCTION

The introduction of Euro-4 and Euro-5 standards has necessitated the use of new technologies such as the development of low emission diesel engines, utilization of particulate filters and catalytic converters providing a significant reduction in diesel particulate matter (PM) emissions. At the same time problems have emerged with an objective evaluation of these emissions by the existing standard method based on gravimetric measurements. In particular, the engines equipped with soot filters have such low levels of PM emissions that gravimetric sample analysis is carried out at the level of the limit of effective range. In this case an error in determining the mass emissions of PM reaches such values that make the entire procedure of testing the engine for a given parameter meaningless in practice.

Therefore, new requirements concerning the assessment procedure of PM emissions from diesel exhaust gases (EG) are emerging. Advanced methods should possess high sensitivity and accuracy at very low concentrations of particles and high speed (high time resolution), allowing continuous measurements while testing the most dynamic cycles.

THE ANALYSIS OF RECENT RESEARCHES AND PUBLICATIONS

Gradual reduction in the permissible levels of PM emissions from diesel engines leads to an increase of the resulting error in measurement of the standardized

ecological index – an average operating emission of particulate matter PM from EG. Thus, shifting from standard Euro 1 to Euro 4, 5 standards of the specified index for automotive diesel decreased by 18 times – from 0,36 to 0,02 g / kW h, and the resulting uncertainty of its determination accordingly increased: from 3 to 20% (6,7 times) - when conducting research in the same lab ; from 12 to 50% (4,2 times) - when research was conducted in different laboratories (Fig. 1) [1].

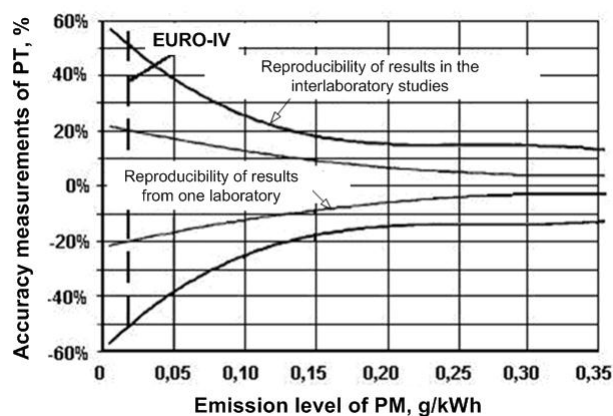

Fig. 1. Measurement error increase in determining the average operating emission of PM in the conditions of reduction of emission standards for diesel engines EG

In order to ensure the required accuracy of determining the mass PM emissions, which are in the range of 0,005 ... 0,02 g / kW · h, the new dynamic methods of measurement of dispersed particles concentrations shall have a sensitivity of 2-5 mcg/m³ [2]. The best known high-precision dynamic inspection techniques for PM emissions include: tapered element oscillating microbalance (TEOM) based on compliance with resonant frequency of a trap, which is used to collect the particles with a mass of material that is captured [3-7]; microbalance with piezoelectric sensing element - quartz crystal, on the faces of which the PM are deposited (Quartz Crystal Microbalance - QCM) [8]; the PT quantitative analysis method using laser-induced EG incandescence (Laser Induced Incandescence - LII), which allows simultaneous measuring of PM mass and number concentration, as well as the sizes of the primary soot particulates – by means of a single instrument [1, 2, 9] and others.

Works on creation of domestic equivalents of modern high precision methods and equipment relating to dynamic measurement of dispersed particles emission from industrial and transportation facilities, in particular from internal combustion engines, are highly relevant [10, 11].

OBJECTIVES

The present article deals with creation and experimental development of a new method and equipment for dynamic measurements of standardized ecological index - the mass PM emissions from diesel EG. The developed method and equipment allows monitoring the instantaneous values of concentration and PT emissions from different types of diesel engines in stationary and unsteady operating conditions, including those of ESC (European steady state cycle) and ETC (European Transient Cycle) cycles [12].

THE MAIN RESULTS OF THE RESEARCH

The essence of the proposed measurement method lies in using the ability of dispersed particles contained in diesel EG to absorb light radiation passing through a stream of a representative gas sample; thus changing the optical density of the sample flow, which has a correlation with the PM concentration [13].

The operating principle of the developed method is as follows (fig. 2).

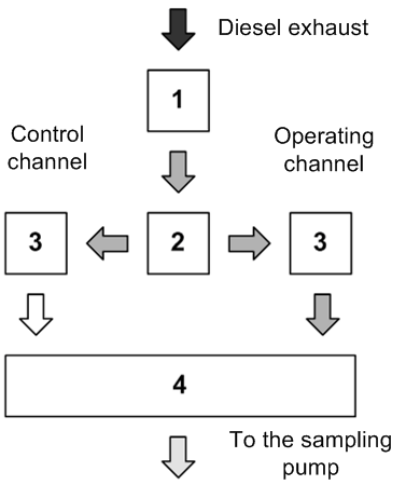

Fig. 2. The principles of the method for dynamic measurements of PM concentrations: 1 – microtunnels; 2 - sample flow rate distribution module; 3 – electric precipitators; 4 - photoelectric PM detector

Before analyzing diesel EG, in order to simulate the natural process of their getting into the atmosphere, they are previously diluted with clean air to a temperature not exceeding 52°C, in the sample preparation and calibration system of the PT concentrations detector (Fig. 3) – namely, microtunnels (MCT). In a special module (Fig. 4), thus prepared gas sample is divided into two streams with equal mass flow rates, one of which is directed to the reference channel and another - to the working path (channel) of the PM concentration meter.

Each of these channels has an electric particulate filter for trapping diesel PM (Fig. 5), the filter in comparative channel being used constantly in the course of taking measurements and the filter in working path being used only when setting zero at the PM concentration detector.

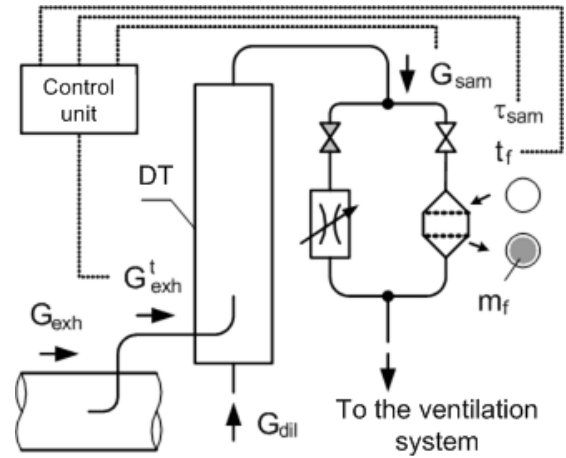

Fig. 3. Basic diagram of sample preparation and calibration system of the PM detector - MCT

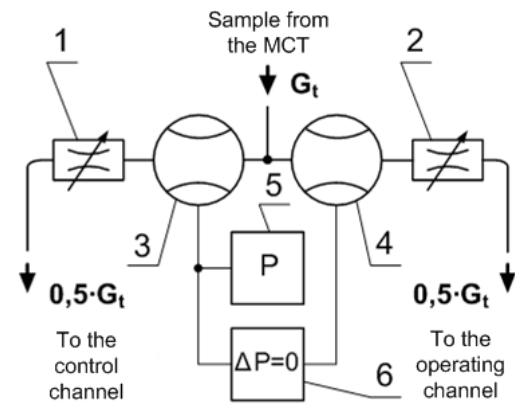

Fig. 4. Basic diagram of the sample flow rate distribution module: 1, 2 – sample flow control devices; 3, 4 –flowmeters; 5, 6 – differential pressure transmitters

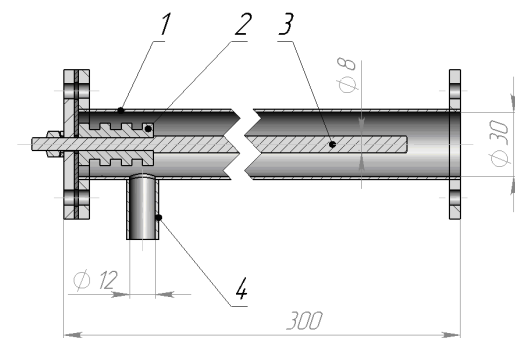

Fig. 5. Electric precipitator of PM: 1 – pipeline; 2 –insulator; 3 – metal rod; 4 – connecting pipe

From the two channels, the flows of gas samples (one of which contains the PM) enter the photoelectric PM detector (Fig. 6), wherein the corresponding optical

densities of flows are determined, the difference between them being a function from the PM concentration in the diesel EG. Setting this function is performed by calibrating photoelectric PM detector under the established procedure.

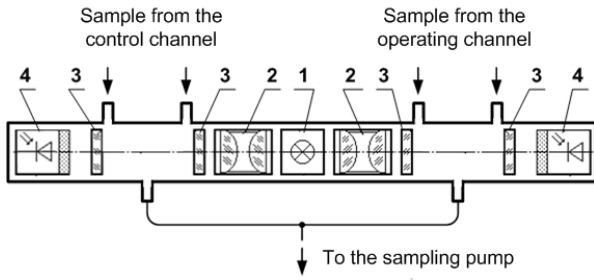

Fig. 6. Basic diagram of the photoelectric PM detector:

1 – light source assembly; 2 – a system of optical lenses; 3 – protective glasses; 4 – light detector with a compensating filter

For implementation of this method the dynamic PM tester brassboard has been developed. It allows monitoring the instantaneous values of the quantitative characteristics of particulate load in diesel EG: concentrations – C_{pt}^d (g/kg), mass PM emissions - PT_{mass}^d (g/h) and specific PM emissions – PT^d (g/kW · h)[14].

Methodology of determination of the C_{pt}^d , PT_{mass}^d and PT^d values provides for the completion of the following algorithm:

1. During tests of a diesel engine on the brake tester equipped with a dynamic PM tester, the instantaneous values of the following parameters are determined:

- the number of revolutions of the engine crankshaft – n (min^{-1}) and torsion moment – M_k (N·m);
- loads on the engine shaft – L (%) = $(M_k / M_{k(\max)}) \cdot 100\%$ ($M_{k(\max)}$ – maximum torque value for a given n);
- rates of change of n and L values within the time interval Δt – $(\Delta n / \Delta t)$, min^{-1}/s and $(\Delta L / \Delta t)$, %/s;
- diesel EG mass flow rate in the exhaust pipe – G_{exh} (kg / h);
- optical densities of the diluted EG sample streams flowing in the working – N_1 (%) and the control – N_0 (%) channels of the dynamic PM detector.

2. Instantaneous values of n and L determine the concentration of PM in diesel EG in the corresponding steady-state operation of the engine:

$$C_{pt}^{\text{st}} = K_{\text{mode}}(n, L) \cdot \text{Ln} \left(1 - \frac{N_1 - N_0}{100} \right)^{-1}, \text{ g/kg}; \quad (1)$$

where: $K_{\text{mode}}(n, L)$ – proportionality factor that depends on the test mode and it is determined during the calibration of the dynamic PM detector.

To determine the value of C_{pt}^{st} , a type of dependence is chosen based on the MIRA (The Motor Industry Research Association) recommendations by the indirect determination of PM concentrations using the index of EG smokiness [13].

3. A correction is determined based on rates of change in the values of n and L for the time interval Δt . The correction takes into account the deviation of the

concentration PM, identified in the transitional and steady state operation of a diesel engine:

$$\Delta C_{pt} = f \left(\frac{\Delta n}{\Delta t}, \frac{\Delta L}{\Delta t} \right), \text{ g/kg}; \quad (2)$$

where: $f((\Delta n / \Delta t), (\Delta L / \Delta t))$ – known experimental dependence determined in the previous tests on diesel steady and unsteady modes with the use of MCT

According to the results of tests of diesel 4CHN12 / 14 it is found that this dependence can be represented by a polynomial of 1st order:

$$\Delta C_{pt} = K_n \left(\frac{\Delta n}{\Delta t} \right) + K_L \left(\frac{\Delta L}{\Delta t} \right), \quad (3)$$

where: K_n and K_L – coefficients determined during calibration of the dynamic PM detector.

4. The dynamic values of the mass – C_{pt}^d and / or volume – $C_{pt(v)}^d$ PM concentrations in diesel EG are determined:

$$C_{pt}^d = C_{pt}^{\text{st}} + \Delta C_{pt}, \text{ g/kg}, \quad (4)$$

$$C_{pt(v)}^d = C_{pt}^d \cdot \frac{\rho_{\text{dil}_0}(q-1) + \rho_{\text{exh}_0}}{q}, \text{ g/mn}^3, \quad (5)$$

where: q – a dilution factor of EG,

$\rho_{\text{dil}_0} = 1,293 \text{ kg/mn}^3$ – density of air at standard conditions,

$\rho_{\text{exh}_0} = 1,295 \text{ kg/mn}^3$ – density of EG at standard conditions. [15].

5. A dynamic value of mass emission of PM from EG is determined:

$$PT_{\text{mass}}^d = C_{pt}^d \cdot G_{\text{exh}}, \text{ g/h}. \quad (6)$$

6. A dynamic value of specific emission of PM from EG is determined:

$$PT^d = \frac{PT_{\text{mass}}^d}{P_e}, \text{ g/(kW} \cdot \text{h)}, \quad (7)$$

where: P_e – the effective power of a diesel engine:

$$P_e = \frac{n \cdot M_k}{9550}, \text{ kW}. \quad (8)$$

Calibration of a dynamic PM detector is carried out in two stages: At the first stage, when the diesel engine operates in steady-state test conditions, the dependence of $K_{\text{mode}}(n, L)$ is identified, it is used in determining the value of C_{pt}^{st} (see formula (1)); At the second stage, when the diesel engine operates in steady-state and unsteady test conditions, the coefficients K_n and K_L are identified, they are used in determining the value of ΔC_{pt} (see formula (3)).

The technique of identification of $K_{\text{mode}}(n, L)$ dependency represents a two-factor experiment, consisting of 4 basic and 3 control tests, the results of which determine a regression equation of the 1st order with the normalized variables X_1 and X_2 (Fig. 7):

$$K_{\text{mode}} = a_0 + a_1 \cdot X_1 + a_2 \cdot X_2 \quad (9)$$

where: a_0, a_1, a_2 – constant coefficients:

$$X_1 = \frac{\bar{n} - \bar{n}_{\text{mid}}}{\Delta n}; \quad X_2 = \frac{\bar{L} - \bar{L}_{\text{mid}}}{\Delta L} - \text{normalized variables},$$

$$\bar{n} = \frac{n - n_{idle}}{n_{nom} - n_{idle}}, \quad \bar{L} = \frac{M_k}{M_{k(max)}} \quad \text{-- relative values of } n$$

and L variables,

$$\bar{n}_{mid} = 0,8, \quad \bar{L}_{mid} = 0,75 \quad \text{-- average values of } \bar{n} \text{ and } \bar{L} \text{ magnitude variation range;}$$

$$\Delta \bar{n} = 0,2; \quad \Delta \bar{L} = 0,25 \quad \text{-- steps of changing the values } \bar{n} \text{ та } \bar{L};$$

n_{idle} and n_{nom} – number of the motor shaft revolutions in no-load running operation and in rated power mode, respectively.

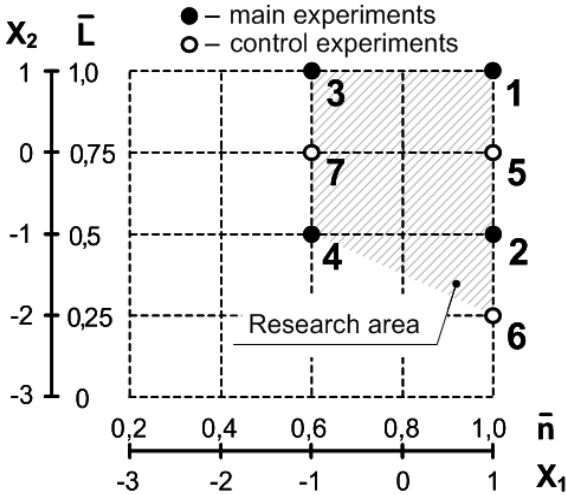

Fig. 7. Plan of the two-factor experiment to determine the dependence of $K_{mode}(n, L)$ in the scope of study: $\bar{n} = 0,6 \dots 1,0$, $\bar{L} = 0,25 \dots 1,0$

The coefficients of the regressional dependence (9) are determined by the results of the basic tests as follows [16]:

$$a_0 = \frac{1}{4} \cdot \sum_{i=1}^4 K_{mode_i} \quad (10)$$

$$a_1 = \frac{1}{4} \cdot (K_{mode1} + K_{mode2} - K_{mode3} - K_{mode4}); \quad (11)$$

$$a_2 = \frac{1}{4} \cdot (K_{mode1} - K_{mode2} + K_{mode3} - K_{mode4}), \quad (12)$$

where: $i=1 \dots 4$ – an index of the basic test;

K_{mode_i} – experimentally determined value of the coefficient K_{mode} in the i -th test:

$$K_{mode_i} = \frac{C_{pt_i}^{st}}{\ln(1 - \Delta N_i / 100)^{-1}}, \quad (13)$$

where: $C_{pt_i}^{st}$ – PM concentration, which is measured using MCT in the i -th test, g / kg;

ΔN_i – the difference of the optical densities of the sample flows in the working and control channels of the dynamic PT detector in the i -th test, %.

The technique of identification of the coefficients K_L and K_n represents 3 cycles of tests conducted in succession (Fig. 8):

A) a cycle of 5 steady-state operating modes of the diesel engine;

B) a cycle of 10 unsteady modes of the diesel engine with a duration $\Delta t = 20$ s (which consists of 4 pairs of basic modes with the same values for one of the variables

- Δn or ΔL , at the zero value of the second variable in each pair and 2 control modes with different values of Δn and ΔL);

C) a cycle of 3 repetitions of unsteady mode with $\Delta \bar{L} = 0,35$, $\Delta \bar{n} = 0$ and different durations Δt : 10, 20 and 30 sec.

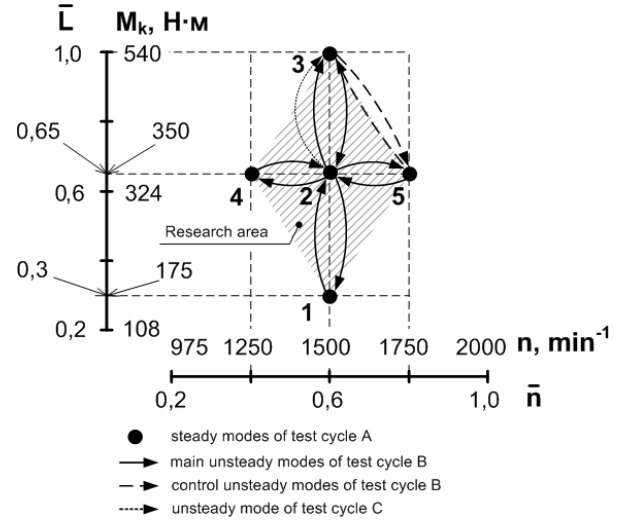

Fig. 8. Steady-state and unsteady test conditions, which are used to determine the coefficients K_L and K_n

Through the execution of the cycle A, the values of C_{pt}^{st} are measured. They correspond to the initial and final values of the parameters n and L of the unsteady test modes implemented in the cycles B and C. In the process the values of n and L vary in a range of 1250 ... 2000 min^{-1} ($\bar{n} = 0,4 \dots 0,8$) and 30 ... 100 % ($\bar{L} = 0,3 \dots 1,0$).

Through the execution of the cycle B, the following coefficients are determined:

- K_L with increasing L by 35% ($\Delta \bar{L} = 0,35$) for different initial values of the variable n (cycles 1→2 and 2→3);

- K_L with decreasing L by 35% ($\Delta \bar{L} = -0,35$) for different initial values of the variable n (cycles 3→2 and 2→1).

- K_n with increasing n by 250 min^{-1} ($\Delta \bar{n} = 0,2$) при різних початкових значеннях величини of the variable L (cycles 4→2 and 2→5);

- K_n with decreasing n by 250 min^{-1} ($\Delta \bar{n} = -0,2$) for different initial values of the variable L (cycles 5→2 and 2→4);

Besides, in control modes, the dependence accuracy is estimated (4) when determining the instantaneous concentration of PM and simultaneously changing the values of n and L .

When processing the test results for each of the specified pairs of the basic diesel engine modes, the average value of the corresponding coefficient, and also its absolute and relative deviation are calculated.

To determine the values of K_n or K_L in each unsteady mode of testing, the following formula shall be used:

$$K_n = \frac{\Delta C_{pt0}}{(\Delta \bar{n} / \Delta t)}, \quad (\text{g} \cdot \text{s}) / \text{kg}, \quad (14)$$

$$K_L = \frac{\Delta C_{pt0}}{(\overline{\Delta L / \Delta t})}, (g \cdot s) / (kg), \quad (15)$$

where: ΔC_{pt0} - deviation of PM concentration, identified in unsteady and steady-state operating modes of the diesel engine by utilizing MCT.

Through the execution of the cycle C, it is possible to determine the average value of the coefficient K_L and its mean square deviation (S_{K_L}) with an increase in the motor shaft load in the range of varying the unsteady mode duration. $\Delta t = 10 \dots 30$ s:

$$K_L = \frac{1}{3} \sum_{i=1}^3 K_{Li}; \quad (16)$$

$$S_{K_L} = \sqrt{\frac{1}{6} \sum_{i=1}^3 (K_L - K_{Li})^2}, \quad (17)$$

where: i - a test mode index;

$n = 3$ - the number of modes in the test cycle.

The results of dynamic measurements of PM in the diesel EG. The dynamic PM tester was installed and experimentally tested on the diesel 4CHN12/14 brake stand.

Calibration of a dynamic PM detector was carried out in two stages, in the course of which the following was found experimentally:

- dependence of the coefficient K_{mode} , which is used in determining the value of C_{pt}^{st} , on the parameters that characterize steady-state modes of testing - n and L ;

- values of the coefficients K_n and K_L , by means of which it is possible to consider the effect of the parameters characterizing the unsteady test mode - $(\Delta n / \Delta t)$ and $(\Delta L / \Delta t)$, on the value of ΔC_{pt} .

To determine the dependence of $K_{mode}(n, L)$, the 2-factor experiment has been conducted (see. fig. 7), its results are shown in Table 1. It should be noted that measuring the value of C_{pt}^{st} was carried out using MCT in each test (the measurement results are designated as C_{pt0}^{st} in Table 1).

Based on the results of basic tests 1-4 using formulas (10) - (12), the coefficients of the regression dependence - polynomial of the 1st order are determined (9): $a_0 = 0,334$, $a_1 = -0,017$, $a_2 = -0,068$.

Thus, for determining the concentration of PM in EG in steady-state conditions of the diesel engine, the dependence is as follows:

- with normalized variables X_1 and X_2 :

$$C_{pt}^{st} = (0,334 - 0,017 \cdot X_1 - 0,068 \cdot X_2) \cdot \text{Ln} \left(1 - \frac{\Delta N}{100} \right)^{-1}; \quad (18)$$

- with relative variables \bar{n} and \bar{L} :

$$C_{pt}^{st} = (0,606 - 0,085 \cdot \bar{n} - 0,272 \cdot \bar{L}) \cdot \text{Ln} \left(1 - \frac{\Delta N}{100} \right)^{-1} \quad (19)$$

Based on the results of control tests 5-7, it was possible to determine the absolute (ΔC_{pt}^{st}), relative (δC_{pt}^{st}) and root-mean-square ($S_{C_{pt}}$) deviations of the calculated values of C_{pt}^{st} (obtained by using dependence (19) on the experimental data. The results of calculations - $\Delta C_{pt}^{st} = -0,005 \dots 0,007$ g/kg, $\delta C_{pt}^{st} = -9 \dots 13\%$, $S_{C_{pt}} = \pm 0,006$ g/kg are comparable to the characteristics of microtunnels MCT accuracy - $\Delta C_{pt}^{st} = \pm 0,005$ g/kg, $\delta C_{pt}^{st} = \pm 8 \dots 10\%$ [17-20], thus indicating that the accuracy of regression dependence is quite satisfactory (19).

To determine the coefficients K_n and K_L , the tests of diesel engine 4CH12/14 were carried out using cycles A, B and C (see fig. 8). In the course of testing the concentrations of PM in EG in steady state - C_{pt0}^{st} and unsteady - C_{pt0}^d conditions of the diesel engine were measured by means of MCT.

In the course of performing the cycle A, the value of C_{pt0}^{st} was determined for 5 steady-state conditions of the diesel engine (fig. 9, table 2), they started and ended unsteady conditions of cycles B and C. The value C_{pt0}^{st} in unsteady modes of testing was determined as the arithmetic average of the initial and final concentrations of PM, determined in the corresponding steady-state conditions.

Table 1. The results of experimental research of the regression dependence $K_{mode}(n, L)$

$N_{g_{doc}}$ s	Parameters of steady-state test modes					The results of measurements and calculations					
	n, min^{-1} (\bar{n})	X_1	$M_k, \text{N} \cdot \text{m}$ (\bar{L})	X_2	P_e, kW	$G_{exh}, \text{kg/h}$	q	$\Delta N, \%$	$C_{pt0}^{st}, \text{g/kg}$	K_{mode}	$\Delta C_{pt}^{st}, \text{g/kg}$ $\delta C_{pt}^{st}, \%$
1	2000 (1)	1	478,0 (1)	1	100,1	712,0	4,29	5,52	0,058	0,2157	0,009 (15,9)
2	2000 (1)	1	239,0 (0,5)	-1	50,0	570,7	3,97	2,52	0,044	0,4175	-0,004 (-8,0)
3	1500 (0,6)	-1	541,2 (1)	1	85,0	483,3	4,49	3,79	0,059	0,3164	-0,006 (-10,5)
4	1500 (0,6)	-1	274,1 (0,5)	-1	43,1	387,2	4,28	1,21	0,021	0,3853	0,001 (5,9)
5	2000 (1)	1	351 (0,75)	0	73,6	652,9	4,49	3,26	0,055	0,3166*	-0,005 (-8,9)
6	2000 (1)	1	119,5 (0,25)	-2	25,0	488,1	4,23	4,46	0,087	0,4520*	0,007 (8,6)
7	1500 (0,6)	-1	407,7 (0,75)	0	64,0	3,63,7	4,44	1,91	0,036	0,3509*	-0,005 (-13,6)

Note. * - calculated values of the coefficient K_{mode} .

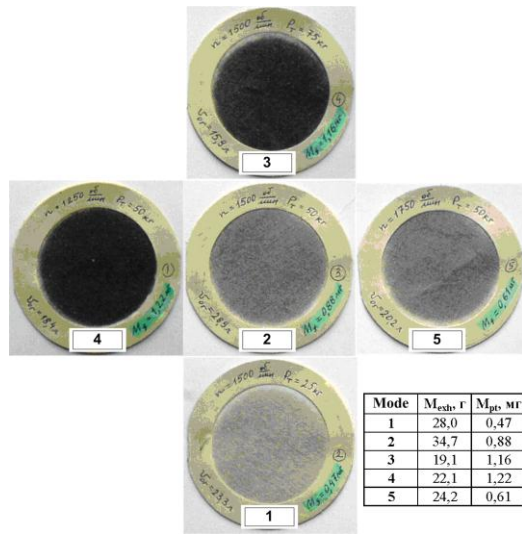

Fig. 9. Filters with PM, which were collected in steady-state test conditions of cycle A

Through the execution of the cycle B, the value of the coefficients K_n and K_L was determined with increasing and decreasing of variables $\Delta \bar{n}$ and $\Delta \bar{L}$, and furthermore, the dependence accuracy was estimated (3) to determine the value ΔC_{pt} . The results of research, obtained by varying the values \bar{n} and \bar{L} in the ranges of $\bar{n} = 0,4 \dots 0,8$ and $\bar{L} = 0,3 \dots 1,0$, and at duration of unsteady modes $\Delta t \approx 20$ s, indicate the following (fig. 10, table 3):

- when one of the variables, $\Delta \bar{n}$ or $\Delta \bar{L}$, increases at a constant value of the second variable, the average values of the coefficients K_n and K_L are 0,96 and 1,79, respectively; the absolute and the relative deviations of K_n and K_L from average values being: $\pm 0,08$ (g·s)/kg, or 8,3% and $\pm 0,06$ (g·s)/kg, or 3,4%, respectively; thus the load L has 1.9 times more significant effect on the value ΔC_{pt} than the number of revolutions of the engine crankshaft n;

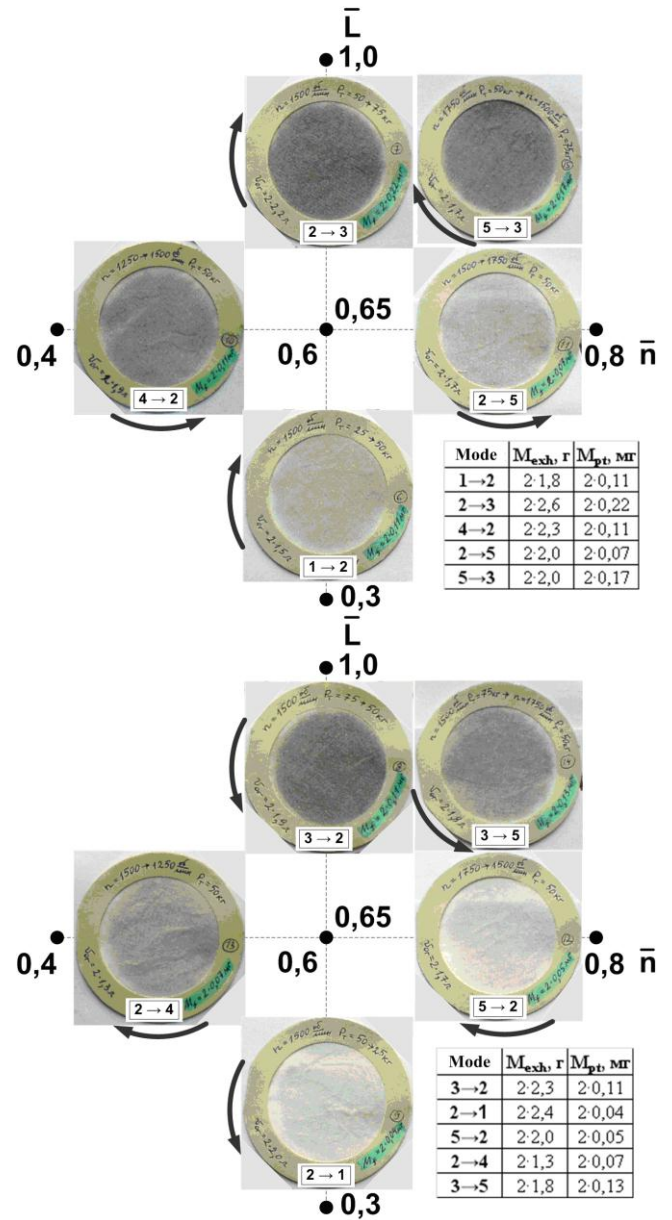

Fig. 10. Filters with PM, which were collected in unsteady conditions of cycle B

Table 2. The results of PM concentration measurement in steady-state test conditions of cycle A

Mode	Operating parameters			The results of measurements and calculations					
	n, min^{-1} (\bar{n})	$M_k, \text{N}\cdot\text{m}$ (\bar{L})	P_e, kW	$G_{exh}, \text{kg/h}$	q	τ_{sam}, s	$G_{sam, r/c}$ (M_{sam}, g)	M_{pt}, mg	$C_{pt0}^{st}, \text{g/kg}$
1	1500 (0,6)	175,7 (0,3)	27,6	403,6	7,13	271,1	0,73 (199,2)	0,47	0,020
2	1500 (0,6)	351,4 (0,65)	55,2	423,3	6,35	301,1	0,74 (220,5)	0,88	0,030
3	1500 (0,6)	527,2 (1,0)	82,8	473,5	6,90	180,9	0,73 (131,9)	1,16	0,073
4	1250 (0,4)	351,4 (0,65)	46,0	332,8	7,01	211,8	0,73 (155,1)	1,22	0,066
5	1750 (0,8)	351,4 (0,65)	64,4	523,8	6,38	211,3	0,73 (154,5)	0,61	0,030

Table 3. The results of experimental research of coefficients K_n and K_L

Mode	Parameters of unsteady test modes				The results of measurements and calculations					
	$\bar{\Delta n}$	$\bar{\Delta L}$	$\Delta t = \tau_{sam}, c$	P_e, kW	$G_{exh}, kg/h$	q	$C_{pt0}^d, (C_{pt0}^{st}) g/kg$	$\Delta C_{pt0}, g/kg$	$K_n^{**}, \frac{g \cdot s}{kg}$	$K_L^{**}, \frac{g \cdot s}{kg}$
1→2	0	0,35	21,09	41,4	413,5	8,43	0,055 (0,025)	0,030	-	1,79
2→3			22,21	69,0	448,4	6,20	0,080 (0,052)	0,028		
3→2	0	-0,35	21,07	69,0	448,4	6,65	0,057 (0,052)	0,005	-	0,00
2→1			21,27	41,4	413,5	6,43	0,020 (0,025)	-0,005		
4→2	0,2	0	21,30	50,6	378,1	6,82	0,058 (0,048)	0,010	0,96	-
2→5			21,33	59,8	473,6	7,81	0,038 (0,030)	0,008		
5→2	-0,2	0	20,83	59,8	473,6	7,47	0,029 (0,030)	-0,001	0,26	-
2→4			21,11	50,6	378,1	9,83	0,054 (0,048)	0,006		
3→5	0,2	-0,35	20,69	73,6	498,7	7,10	0,064 (0,052)	0,012 0,009*	0,96	0,00
5→3	-0,2	0,35	20,11	73,6	498,7	7,48	0,079 (0,052)	0,027 0,031*	0,00	1,79

Note. * – calculated values of ΔC_{pt0} , obtained through dependence (3); ** – arithmetic mean value by results of 2 measurements of the coefficient .

- when one of the variables, $\bar{\Delta n}$ or $\bar{\Delta L}$, decreases at a constant value of the second variable, the average values of the coefficients K_n and K_L are not significant and they do not have to be taken into account, since the deviations of PM concentrations, determined in unsteady and steady-state conditions of the tests are $\Delta C_{pt0} = -0,005 \dots 0,006$ g/kg, that is comparable with sensitivity limit of the MCT - $\pm 0,005$ [16];

- the absolute deviations of calculated values of ΔC_{pt} , determined through dependence (3) on the experimental data obtained in the course of performing 2 control unsteady modes, are -0,003 g/kg and 0,004 g/kg, that is comparable with sensitivity limit of the MCT. It confirms the significance of the obtained values of the coefficients K_n and K_L , as well as practical suitability of dependence (3) for determining the ΔC_{pt} value.

Through the execution of the cycle C, it became possible to study the value of the coefficient K_L with the growth of load L and constant value of the number of revolutions of the engine crankshaft n in the range of variation of the unsteady mode duration $\Delta t = 10 \dots 30$ s.

Results of the research showed the following (Fig. 11):

- if Δt increases, the divergence of PM concentrations C_{pt}^d and C_{pt}^{st} decreases; thus, when Δt increases from 10 to 30 s, the value of ΔC_{pt} decreases 1,8 times;

- In the investigated range of variation $\Delta t = 10 \dots 30$ s the coefficient K_L can be assumed to be constant, the average value of which amounts to 1,575; wherein root-mean-square deviation of the results of measurements K_L is $\pm 0,105$ (g·s)/kg, which is 6,7%.

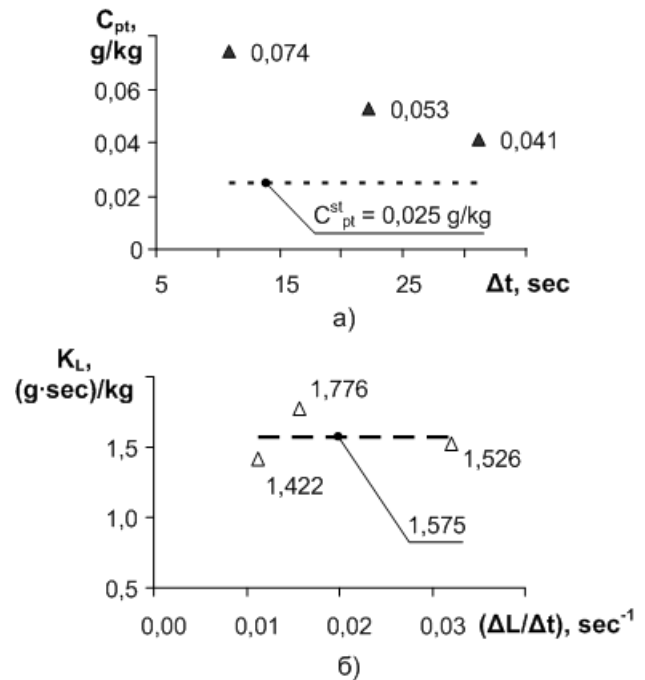

Fig. 11. The results of studies on the effect of unsteady mode duration Δt on values ΔC_{pt} (a) and K_L (b) in the course of executing cycle C

Thus, taking into account the selected type of regressional dependence $\Delta C_{pt} = f((\Delta n/\Delta t), (\Delta L/\Delta t))$ (see formula (3)) and the results of experimental studies of coefficients K_n and K_L , the formula for determining the value of ΔC_{pt} is:

$$\Delta C_{pt} = 0,96 \left(\frac{\Delta \bar{n}_+}{\Delta t} \right) + 1,575 \left(\frac{\Delta \bar{L}_+}{\Delta t} \right), \text{ g/kg,}$$

where: $\Delta \bar{n}_+$ and $\Delta \bar{L}_+$ – positive values of $\Delta \bar{n}$ and $\Delta \bar{L}$.

CONCLUSIONS

1. Modern methods of dynamic measurement of mass emissions of PM from G_{exh} of diesel power plants have been analyzed: tapered element oscillating microbalance-TEOM; microbalance with piezoelectric sensing element (Quartz Crystal Microbalance - QCM); the PM quantitative analysis method using laser-induced EG incandescence (Laser Induced Incandescence - LII) and others. The requirements to the accuracy of these methods are defined when measuring the concentration of PT - 2-5 mcg/m³.

2. A concept and a model sample of the dynamic PM emission tester, which allows control of instantaneous concentration, mass and specific PM emissions from various types of diesel engines is developed. This measuring device uses the PM's ability to absorb light radiation, that leads to a change in the optical density of the flow of the sample analyzed, which has a correlation relationship with the concentration of PM.

3. Experimental research of the dynamic PM tester based on the diesel 4CHN12/14 brake tester has been conducted. It demonstrates practical suitability of the equipment designed to determine the instantaneous values and concentrations of PM emissions in the steady-state and unsteady operation modes of a diesel engine.

REFERENCES

- Burtscher H. 2001.** Literature Study on Tailpipe Particulate Emission Measurement for Diesel Engines // done for the Particle Measurement Programme (PMP) for BUWAL/GRPE . Fachhochschule Aargau, University of Applied Science, Windisch, Switzerland.
- Anderson J.D. 2003.** UK Particle Measurement Programme. Phase 2 / Heavy Duty Methodology Development // Final Report.– Ricardo Consulting Engineers Ltd.
- Tsugio A., Tatsuji S., Morimasa H. 1989.** Particulate matter emission characteristics under transient pattern driving // SAE Techn. Pap. Ser. №890468.
- MacDonald J.C., Barsik N.J., Gross G.P. and others. 1984.** Status of diesel particulate measurement methods // SAE Techn. Pap. Ser. № 840345.
- Keizo S., Osamu S. 1990.** The measurement of diesel particulate emissions with tapered element oscillating microbalance and an opacimeter // SAE Techn. Pap. Ser. № 900644.
- Oswald M., Nunnemann F. 1988.** Die dynamische Partikelmessung ein notwendiges Hilfsmittel bei der Entwicklung von Dieselmotoren // VDI-BER. –№ 681.
- Andersson J.D. 2002.** UK Particle Measurement Programme. Phase 1 / Heavy Duty Methodology Development // Final Report. – Ricardo Consulting Engineers Ltd. (3.1)
- Measurements in industry. Reference book. Bk. 1. Theoretical Foundations / Under the editorship of P. Profos. - M.: Metallurgy. 1990 (in Russian).
- Schraml S., Will S., Leipertz A. 1999.** Simultaneous measurement of soot mass concentration and primary particle size in the exhaust of DI diesel engine by time-resolved laser-induced incandescence (TIRE-LII) / SAE Techn. Pap. Ser. № 990146.
- Dvulit, O. Bojko. 2014.** Towards sustainable transport in Ukraine: main obstacles and directions of development // ECONTECHMOD/ Vol. 3, №2.
- Batluk V. A. and Romantsov E. V. and Klymets V. M. 2013.** The problem of highly effective cleaning of air from dust // ECONTECHMOD/ Vol. 2, №2.
- Regulation No 49. Revision 5. Uniform provision concerning the approval of compression ignition (C.I.) and natural gas (NG) engines as well as positive-ignition (P.I.) engines fuelled with liquefied petroleum gas (LPG) and vehicles equipped with C.I. and NG engines and P.I. engines fuelled with LPG, with regard to the emissions of pollutants by the engine. - United Nations Economic and Social Council Economic Commission for Europe Inland Transport Committee Working Party on the Construction of Vehicles. – E/ECE/TRANS/505. – 4 May 2011.
- Hardenberg H., Albrecht H. 1987.** Grenzen der Rubmassbestimmung aus optischen Transmessungen / MTZ: Motortechn. Z.- № 2.
- Marchenko A.P., Parsadanov I.V., Polivianchuk A.P. 2012.** Effect of automotive-tractor diesel operation modes on emissions of particulates with exhaust gases / Herald of National Transport University. - № 25. (in Russian).
- Mikheev M.A., Mikheyeva I.M. 1977.** Fundamentals of heat transfer / 2nd Edition, M.: "Energy". (in Russian).
- Adler Y.P., Markova E.V., Granovsky Y.V. 1976.** Design of experiment in the search for the optimal conditions / M.: "Science". (in Russian).
- Polivianchuk A. P., Parsadanov I.V., Rykova I.V. 2009.** Determination and analysis of the levels of emissions of particulates with exhaust gases of automotive diesel engine in steady running / Internal combustion engines. - №1. (in Russian).
- Polivianchuk A.P. 2010.** Improving accuracy of gravimetric measurement method for specific emission of particulate matter with exhaust gases of a diesel engine / Internal combustion engines. - №2. (in Russian).
- Polivianchuk A.P. 2012.** Uncertainty estimate in the results of measurement of particulate emissions during the environmental testing of diesel engines / Visnik of the Volodymyr Dahl East Ukrainian national university. — №5 (176), Part 2. (in Russian).
- Polivianchuk A.P., Lvov S.O. 2013.** Determining the regression dependence to assess the solids content in exhaust gases of diesel engine

Visnik of the Volodymyr Dahl East Ukrainian national university. - - № 17 (206), Part1. (in Russian).

СОЗДАНИЕ И ЭКСПЕРИМЕНТАЛЬНЫЕ
ИССЛЕДОВАНИЯ ДИНАМИЧЕСКИХ
КОНЦЕНТРАЦИЙ ИЗМЕРЕНИЯ ЧАСТИЦ
В ВЫХЛОПНЫХ ГАЗАХ ДИЗЕЛЬНЫХ
ДВИГАТЕЛЕЙ

А. Поливианчук, І. Парсаданов, О. Голкина

Аннотация. Проанализированы современные методы динамического измерения массы выбросов твердых частиц из выхлопных газов дизельных электростанций и требования к точности высокой

скорости отклика. Разработаны принципиальная схема, а также конструкция тестера для измерения динамических выбросов твердых частиц, который позволяет контролировать мгновенное значение концентрации, массы и конкретных выбросов твердых частиц из различных типов бензиновых и дизельных двигателей. Экспериментальное исследование тестера динамической твердых частиц показывает свою практическую пригодность для определения выбросов твердых частиц в постоянных и нестационарных режимах работы дизеля.

Ключевые слова: дизель, тормозной стенд, выхлопные газы, твердые частицы (частицы), концентрация, масса выбросов, динамические измерения.